



# MPSA144

## NPN SILICON TRANSISTOR

### HIGH VOLTAGE TRANSISTOR

■ FEATURES

- \* Collector-Emitter Voltage:  $V_{CE0}=500V$
- \* Collector Current up to 300mA

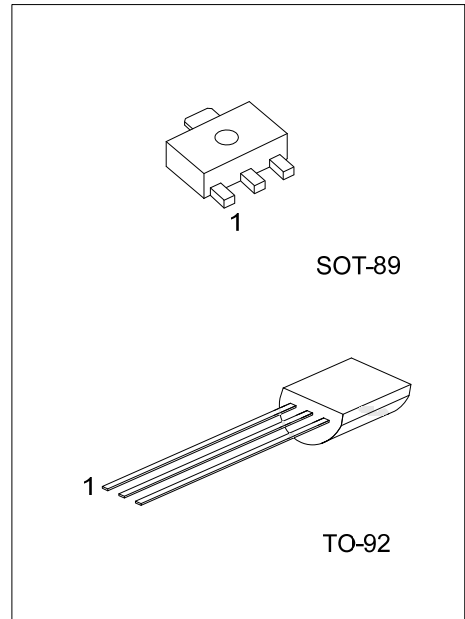

■ ORDERING INFORMATION

Ordering Number		Package	Pin Assignment			Packing
Lead Free	Halogen Free		1	2	3	
MPSA144L-AB3-R	MPSA144G-AB3-R	SOT-89	B	C	E	Tape Reel
MPSA144L-T92-B	MPSA144G-T92-B	TO-92	E	B	C	Tape Box
MPSA144L-T92-K	MPSA144G-T92-K	TO-92	E	B	C	Bulk

Note: Pin Assignment: B: Base C: Collector E: Emitter

<p>MPSA144G-AB3-R</p>	<p>(1) R: Tape Reel, B: Tape Box, K: Bulk                  (2) AB3: SOT-89, T92: TO-92                  (3) G: Halogen Free and Lead Free, L: Lead Free</p>
-----------------------	---

■ MARKING

SOT-89	TO-92

### ■ ABSOLUTE MAXIMUM RATING

PARAMETER		SYMBOL	RATINGS	UNIT
Collector-Base Voltage		$V_{CBO}$	500	V
Collector-Emitter Voltage		$V_{CEO}$	500	V
Emitter-Base Voltage		$V_{EBO}$	6	V
Collector Current		$I_C$	300	mA
Collector Dissipation ( $T_A=25^\circ\text{C}$ )	SOT-89	$P_C$	500	mW
	TO-92		625	mW
Operating Junction Temperature		$T_J$	-40 ~ +150	$^\circ\text{C}$
Storage Temperature		$T_{STG}$	-40 ~ +150	$^\circ\text{C}$

Notes: 1. Absolute maximum ratings are those values beyond which the device could be permanently damaged.

Absolute maximum ratings are stress ratings only and functional device operation is not implied.

2. Device mounted on FR-4 substrate PC board, 2oz copper, with 1inch square copper plate.

### ■ THERMAL DATA

PARAMETER		SYMBOL	RATINGS	UNIT
Junction to Ambient	SOT-89	$\theta_{JA}$	250	$^\circ\text{C/W}$
	TO-92		200	$^\circ\text{C/W}$

Note: Device mounted on FR-4 substrate PC board, 2oz copper, with 1inch square copper plate.

### ■ ELECTRICAL CHARACTERISTICS ( $T_J=25^\circ\text{C}$ , unless otherwise specified)

PARAMETER	SYMBOL	TEST CONDITIONS	MIN	TYP	MAX	UNIT
Collector-Base Breakdown Voltage	$BV_{CBO}$	$I_C=100\mu\text{A}, I_E=0$	500			V
Collector-Emitter Breakdown Voltage	$BV_{CEO}$	$I_C=1\text{mA}, I_B=0$	500			V
Emitter-Base Breakdown Voltage	$BV_{EBO}$	$I_E=100\mu\text{A}, I_C=0$	6			V
Collector-Base Cutoff Current	$I_{CBO}$	$V_{CB}=500\text{V}, I_E=0$			0.1	$\mu\text{A}$
Collector Cutoff Current	$I_{CES}$	$V_{CE}=500\text{V}, I_B=0$			0.5	$\mu\text{A}$
Emitter-Base Cutoff Current	$I_{EBO}$	$V_{EB}=4\text{V}, I_C=0$			0.1	$\mu\text{A}$

#### ON CHARACTERISTICS

DC Current Gain (Note)	$h_{FE}$	$V_{CE}=10\text{V}, I_C=1\text{mA}$	80	155		
		$V_{CE}=10\text{V}, I_C=10\text{mA}$	82	157		
		$V_{CE}=10\text{V}, I_C=50\text{mA}$	45	110		
		$V_{CE}=10\text{V}, I_C=100\text{mA}$	20	36		
Collector-Emitter Saturation Voltage	$V_{CE(SAT)}$	$I_C=1\text{mA}, I_B=0.1\text{mA}$		86	130	mV
		$I_C=10\text{mA}, I_B=1\text{mA}$		68	110	mV
		$I_C=50\text{mA}, I_B=5\text{mA}$		100	130	mV
Base-Emitter Saturation Voltage	$V_{BE(SAT)}$	$I_C=10\text{mA}, I_B=1\text{mA}$		0.69	0.75	V

#### SMALL-SIGNAL CHARACTERISTICS

Current Gain Bandwidth Product	$f_T$	$V_{CE}=20\text{V}, I_C=10\text{mA}, f=100\text{MHz}$	50			MHz
--------------------------------	-------	---	----	--	--	-----

Note: Pulse test:  $P_w \leq 300\mu\text{s}$ , Duty Cycle  $\leq 2\%$ .

## TYPICAL CHARACTERISTICS

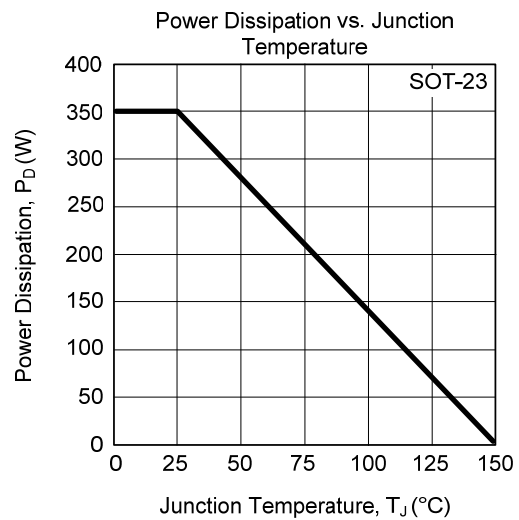
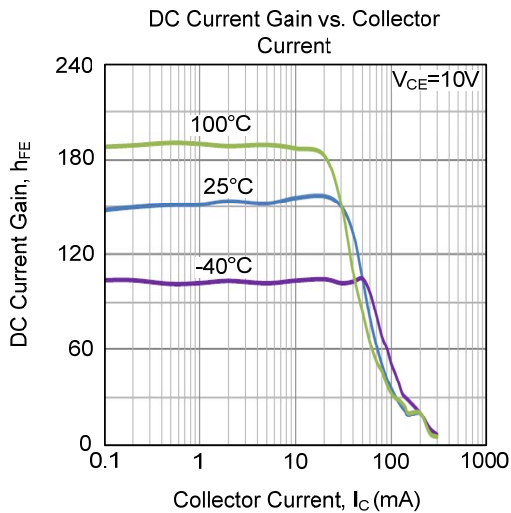
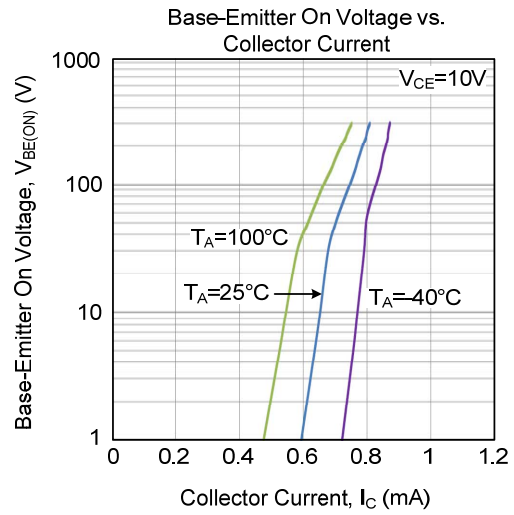
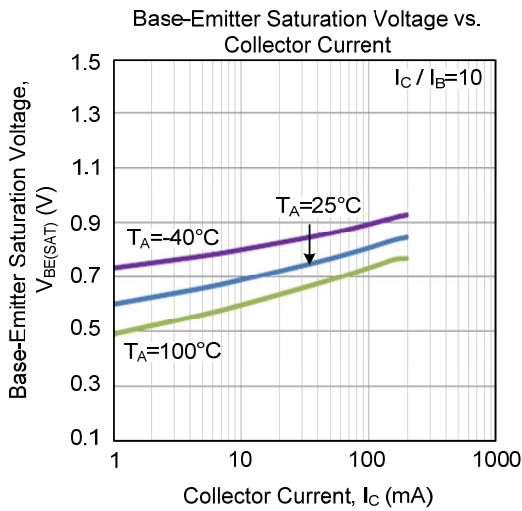
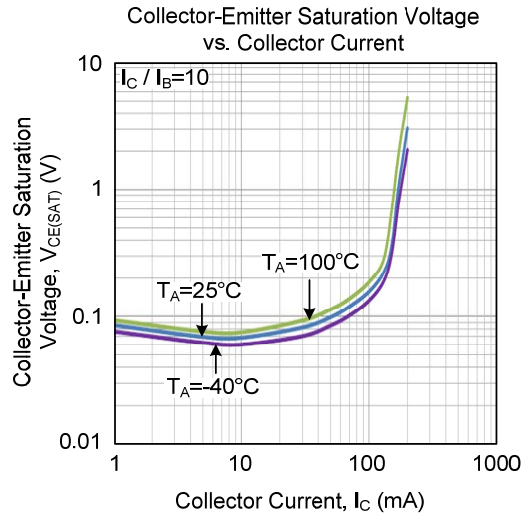
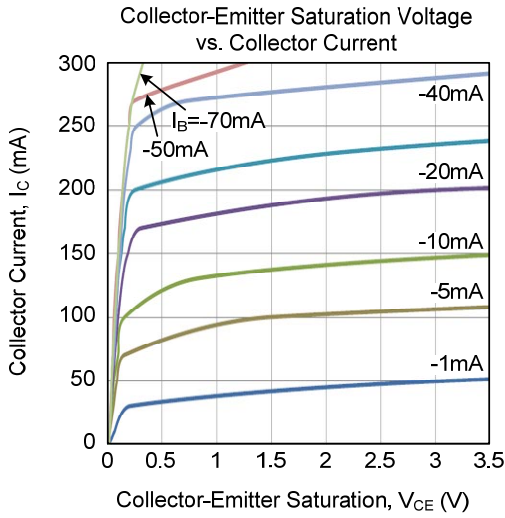

■ TYPICAL CHARACTERISTICS

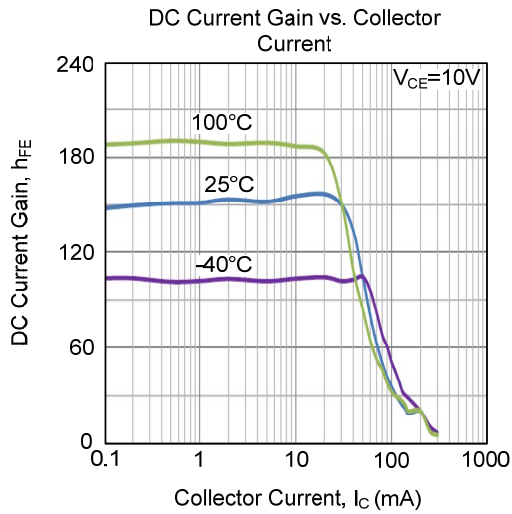

UTC assumes no responsibility for equipment failures that result from using products at values that exceed, even momentarily, rated values (such as maximum ratings, operating condition ranges, or other parameters) listed in products specifications of any and all UTC products described or contained herein. UTC products are not designed for use in life support appliances, devices or systems where malfunction of these products can be reasonably expected to result in personal injury. Reproduction in whole or in part is prohibited without the prior written consent of the copyright owner. UTC reserves the right to make changes to information published in this document, including without limitation specifications and product descriptions, at any time and without notice. This document supersedes and replaces all information supplied prior to the publication hereof.